

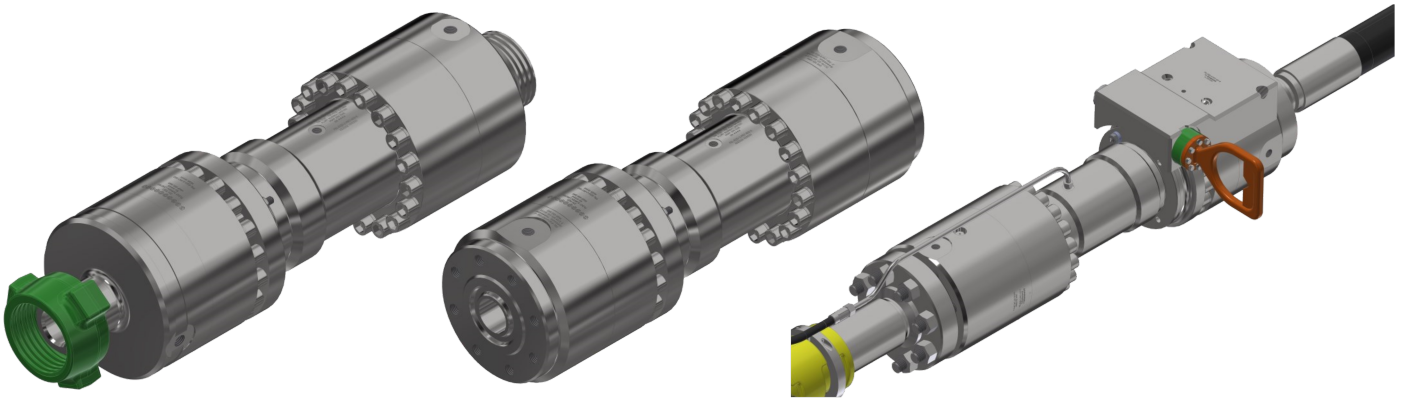

# MID LINE WEAK LINK

## Emergency Quick Disconnect (EQD) Device

The Mid Line Weak Link, available for sale or rental, is a full-bore, straight through, pressure balanced emergency quick disconnect (EQD) device suitable for operating in water up to 10000ft deep, installed on flexible hoses. In the event of an over pull on the hose, or hydraulic disconnect the unit will separate and internal barriers will close off to prevent discharge of fluid to the marine environment.



### OPERATION

The Flint Subsea Mid Line Weak Link EQD systems have extensive track record and have been operating for several large profile intervention and pumping operators in 5 continents for over 5 years.

Mounted mid-line in a hose, either subsea or topside, the device is held together with pre stressed tension pins. The pressure balanced design features integrated check valves.

When the hose tension exceeds the pin strength, the disconnect sequence is initiated. Once disconnected, the valves close, preventing discharge from both ends of the connector. An optional valve prevents ingress of water to the bore.

Each unit\* is supplied with integrated hold back points allowing them to be tied back to subsea or topside structures.

The unit is also available with hydraulic override capability. Simply attach a hydraulic input to the side of the device and pump it apart and avoid tensile loads damaging the hose.

\* Integrated only on 10KSI units. Optional extra on all other devices.

SPECIFICATIONS	
Max Working Pressure	15'000 PSI [1034 Bar]
Operating Temp Range	14°F to 180°F [-10°C to +82°C]
Maximum Depth	10'000 ft [3048m]
Material Class	API HH available
Material Certification	BS EN 10204 3.1
Specification Level	PSL3 (3G available)
Standard	API 17G
Qualification	API 6A PR2
Hold Back Points	2 x M20 each end
Hydraulic Disconnect	Included
Tension Pin Break load	1650lbs to 11000lbs [0.75 Te to 5 Te]
Ingress Valve	Available as option to prevent ingress of environment to device

Bore Size	Pressure Rating	Length	Diameter	Total Weight	Male Weight	Female Weight
2"	5'000 [345 Bar]	23.2" [590mm]	6.3" [160mm]	176lbs [80kg]	75lbs [34kg]	101lbs [46kg]
2"	10'000 [690 Bar]	29.5" [750mm]	8.7" [220mm]	223lbs [101kg]	101lbs [46kg]	121lbs [55kg]
2"	15'000 [1034 Bar]	33" [840mm]	9.0" [230mm]	419lbs [190kg]	176lbs [80kg]	243lbs [110kg]
3"	10'000 [690 Bar]	37" [935mm]	11" [282mm]	723lbs [328kg]	250lbs [113kg]	414lbs [188kg]
4"	1'400 [100 Bar]	28" [700mm]	9.8" [250mm]	265lbs [120kg]	160lbs [73kg]	104lbs [47kg]

